



Thomas Broadbent and Sons Limited
Sugar Division

Information Sheet SI/01/1

Solving Vibration Problems in Batch Sugar Centrifuges

This Information Sheet gives guidance on identifying and correcting out of balance and vibration problems in pendulum suspended batch sugar centrifuges. An understanding of the types of vibration and instability that can occur and the reasons for them will help in solving problems.

BATCH CENTRIFUGE SUSPENSION

The load in the basket of a centrifuge will always be slightly out of balance. Sugar centrifuges usually spin at a speed giving a separating effect of about 1000 'G' (one thousand times normal gravity) so each 1 kg out of balance will give a corresponding centrifugal force of about 1 Tonne which acts radially outwards and rotates at the speed of the centrifuge.

In a centrifuge with a rigidly mounted shaft and basket as shown in Figure 1, all of this rotating force is transmitted directly to the casing and would quickly damage the bearings and shake the supporting structure.

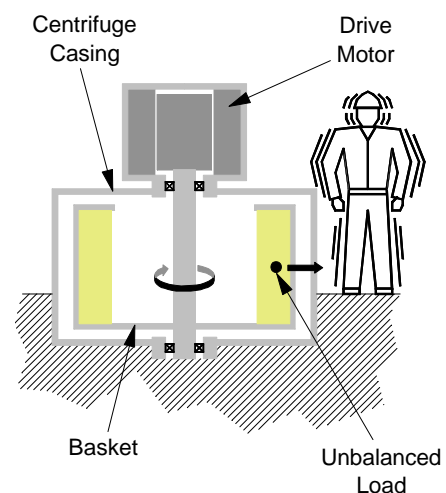

Figure 1 Rigid Bearing Centrifuge

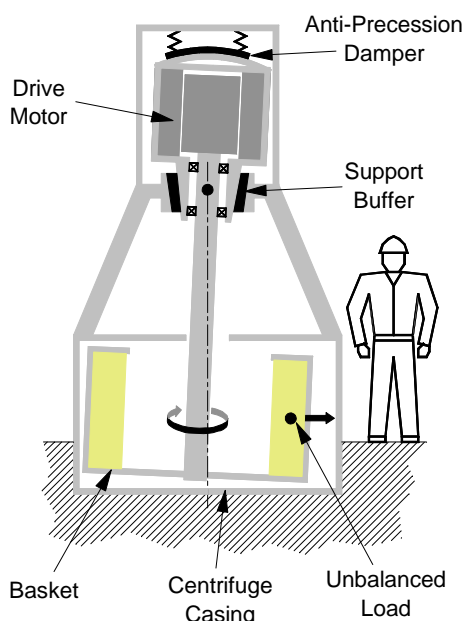
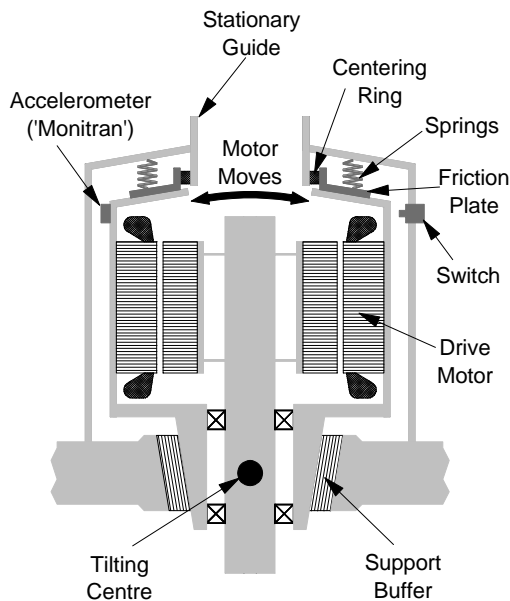

Figure 2 Pendulum Suspended Centrifuge

For this reason, Broadbent batch sugar centrifuges are pendulum suspended with the rotating assembly hanging from a conical rubber **Support Buffer** as shown in Figure 2. Provided that the rotating speed is above the swinging resonance, the basket swings slightly in the opposite direction to the position of the unbalance to find a better balanced axis of rotation and thus reduce the transmission of forces to the support structure. The swinging resonance is the frequency that the rotating assembly would naturally swing if it were pushed slightly to one side and then released. To ensure that this self balancing action occurs whenever the basket is loaded, *the speed at which product is fed into the centrifuge must always be substantially above the swinging resonant frequency.*

TYPES OF VIBRATION AND INSTABILITY

Consider a pendulum suspended centrifuge such as that in Figure 2 spinning with an out of balance in the basket. The self balancing action means that only a fraction of the out of balance force is transmitted to the frame and structure but this residual transmitted force can be felt as vibration at the same frequency that the shaft rotates. This is known as **Shaft Rate Vibration**. Since the whole rotating assembly tilts slightly in a fixed orientation relative to the unbalance, as the centrifuge rotates, the basket and motor appear to move side to side at the same speed as the shaft. A vibration sensor (accelerometer) attached to the top of the motor can detect this small movement (around 0.1 to 0.2 mm per 1 kg unbalance in the basket). This acceleration is proportional to the amount of unbalance in the basket and to the corresponding stresses in the basket and shaft caused by the unbalance. The vibration sensor can therefore be used to protect the basket and shaft against excessive stresses.



Feeding is usually carried out at a low rotational speed but higher than the swinging resonant speed. During feeding, the centrifugal force causes the product to climb up the inside of the basket and also flow around the basket to produce an even cake thickness. While the product is flowing inside the basket, the basket tends to swing by quite large amounts and this is known as **Gyration**. At the same time, the centrifugal force causes liquor to start to purge out of the product. The higher the rotational speed, the faster the cake purges. The aim is to feed more product into the basket just fast enough to replace the liquor lost by purging and thus keep the cake mobile long enough to allow it to flow and balance itself.

Figure 3 Details of Pendulum Suspension

If the cake purges too quickly during feeding (e.g. if the feeding speed is too high or the feeding rate is too low), the cake solidifies before it can balance itself and this is the cause of unbalance and *Shaft Rate Vibration* at high speed. On the other hand, if the feed speed is too low the cake will remain fluid longer and the rotating assembly will be closer to the swing resonance which will both tend to increase *Gyration*. ***Increasing the feed speed reduces Gyration during feeding but increases Shaft Rate Vibration at high speed. Reducing the feed speed decreases Shaft Rate Vibration but increases Gyration.*** To some extent it is possible to compensate for a high feed speed by increasing the feeding rate or a low feed speed by reducing the feeding rate.

If the product contains a lot of very small crystals (e.g. A 'false grain' masseccuite) and a high proportion of liquor or if the filtering screen is blinded by product or contaminants blocking the perforations, the liquor may have difficulty in purging out of the cake. Instead, a layer of liquor will form on the surface of the cake. Waves will start to form in this layer of liquid and when the speed of these waves synchronises with the rotational speed of the basket the basket will suddenly 'kick' sideways and hit the casing. This is known as a **Liquor Loading Instability** and can cause serious damage.

Liquor Loading Instabilities occur so suddenly that the centrifuge control system is unable to take any corrective action and for this reason they are potentially dangerous.

When spinning at high speed, the centrifuge rotating assembly is susceptible to **Gyroscopic Precession**. This is the tendency for the axis of any rotating object to start slowly orbiting with a gradually increasing amplitude and can be seen in the ‘wobbling’ of a toy spinning top. If unchecked, the basket eventually impacts the casing causing serious damage. This is prevented by a plate with a friction lining being pushed onto the top of the motor by spring pressure (see Figure 3). This **Anti-Precession Damper** system also helps to reduce the *Gyration* movements during feeding. Any sign that the rotating assembly is slowly wandering in circles during spinning is an indication that the Anti-Precession Damper requires maintenance.

It is clear from the above that many vibration and instability problems arise from poor quality product feed or badly adjusted feed speed and feed rate. Figure 4 summarises some typical problems and the means of correcting them.

Figure 4 Feeding Problems

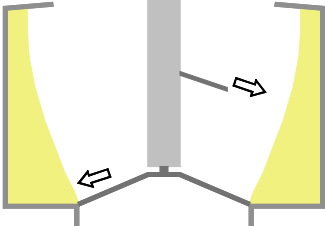
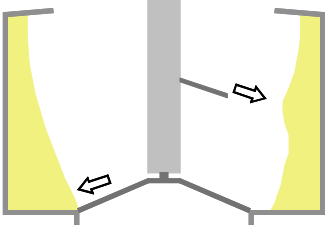
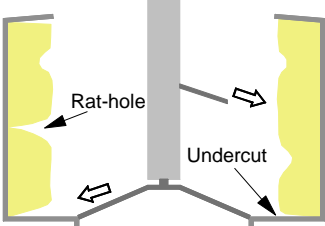
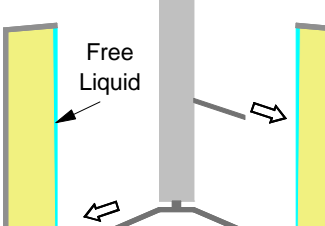
| <i>Symptom</i> | <i>Appearance</i> | <i>Cause</i> | <i>Action</i> |
|--|--|--|--|
| Unable to fill basket. High <i>Gyration</i> during feeding. Low <i>Shaft Rate</i> <i>Vibration</i> at high speed | Cake tapers from top to bottom but is even around basket  | Insufficient ‘G’ for product to climb basket | Increase feed speed. |
| Unable to fill basket. Cake is unbalanced giving high <i>Shaft Rate</i> <i>Vibration</i> at high speed. | Cake thicker where product first contacts basket  | Product purging too quickly and unable to flow to distribute itself evenly around the basket. | Decrease feed speed and/or increase feed rate. |
| Excessive <i>Shaft Rate</i> <i>Vibration</i> at high speed. | Cake undercut at top or bottom. Depressions or holes at random positions.  | ‘Rat holing’ past edges or through holes in filtering screen. | Check fit of screens in basket. Check screens not torn or holed. Check wash pipe not dribbling on basket bottom. |
| Basket suddenly impacts casing during acceleration due to <i>Liquor Loading Instability</i> | Free liquid visible on surface of cake.  | Product sedimenting instead of purging. Waves set up in liquid layer cause a sudden instability. | Check screens not blocked. Check quality of product feed for high free liquor content, excessively small crystals. |

AUTOMATIC PROTECTION DEVICES

All Broadbent batch sugar centrifuges are fitted with two types of sensor which are connected to the control system to provide automatic protection against vibration or instability problems damaging the centrifuge or presenting a hazard to operators. These are shown on Figure 3.

The **Out of Balance (OOB) Switch** is a robust mechanical switch which is designed to detect large amplitude, slow speed movements of the rotating assembly due to *Gyration* or *Precession*. The gap between the switch and a striker plate on the top of the motor is set to activate the switch if the rotating assembly swings enough to take up about 50% of the clearance between the basket bump ring and the casing curb ring

The **Vibration Monitor** is a simple accelerometer with a built in filter and amplifier to respond only to shaft rate movement at the rotational speed of the centrifuge. It is designed to detect the small amplitude, high speed *Shaft Rate Vibration* movements of the centrifuge caused by *Out of Balance* in the basket. The vibration monitor gives a continuous reading of vibration acceleration in 0.01 G rms on the operator interface. This reading is almost exactly proportional to the stresses in the spindle and basket and the control system is designed to automatically take protective action if the vibration amplitude exceeds a preset amplitude for more than a preset time. Two sets of vibration levels are normally preset - **Hi Vibration** and **Hi Hi Vibration**.

The action taken by the control system depends on the position in the cycle when the OOB switch or vibration monitor is activated.

SOLVING PERSISTENT VIBRATION AND INSTABILITY PROBLEMS

The most likely cause of regular OOB switch and Vibration Monitor trips (automatic stops) is that the process parameters being used are incorrect for the product being processed. In particular, the rotational speed at feeding and the rate of feeding as controlled by the feed valve opening have a large effect on the ability of the centrifuge to balance itself. If the consistency of the product being fed varies significantly, these parameters must be changed. Refer to Figure 4.

A less likely cause of problems is some mechanical defect in the centrifuge. This will only be the case if the problems persist when the centrifuge is run empty.

Figure 5 lists symptoms, causes and recommended actions for correcting all types of vibration and instability problems. Work through Figure 5 methodically as follows,

- (a) Is the *Out of Balance Switch* or *Vibration Monitor* faulty?
- (b) Does the problem persist when the centrifuge is run empty?
- (c) Is the problem *Shaft Rate Vibration*, *Gyration*, *Liquor Loading Instability* or *Precession* and when does it occur?

Note that any changes to feed speed should be made slowly, no more than 5 rpm at a time and the feed speed should never be less than 25 rpm above the swinging resonance

Figure 5 Diagnosis of Vibration and Out of Balance Problems

| <i>Symptom</i> | <i>Causes</i> | <i>Actions</i> |
|---|--|---|
| Trips occur without apparent excessive vibration or swinging | Faulty OOB Switch | Check OOB Switch Gap (See drawings or manual) Check OOB Switch not damaged |
| | Faulty Vibration Monitor | Check Monitor Wiring and Earthing Check Monitor Calibration |
| <i>Shaft Rate</i> Vibration persists when centrifuge run empty without product in basket | Debris in Basket | Check there are no remnants of product left in basket Check there are no foreign objects in basket |
| | Mechanical Fault | Check there is no debris trapped between the spindle and basket flange faces and check basket bolts are tight Check spindle is not bent or damaged Check basket is not damaged |
| Excessive Gyration during feeding | Product feed has high liquor content or feed rate too high causing heavy impact on basket | Reduce feed rate by reducing feed valve opening Check for excessive liquor in fed product |
| | Feed speed is too low, close to swinging resonance of centrifuge | Increase feed speed |
| | Anti-precession damper defective | Check damper spring settings (see drawings or manual) Check friction linings on damper plate not loose or worn Check centering ring is a tight fit on fan ducting |
| Basket 'kicks' at start of acceleration after feeding | Product cake is too fluid and mobile due to insufficient purging during feeding | Increase feed speed Reduce feed rate by reducing feed valve opening Change purge settle delay from zero to a few seconds Check for large quantities of small crystals or excessively viscous liquor in fed product |
| Sudden <i>Liquor Loading</i> <i>Instability</i> during acceleration to spin | Product purges poorly due to small crystals or high liquor content allowing a visible layer of liquor to form on cake surface | Improve quality of fed product Adjust feed limiter to reduce cake thickness Change purge settle delay from zero to 30-60 seconds Reduce feed rate by reducing feed valve opening Increase feed speed (with caution) |
| | SAFETY HAZARD Filtering screen is blocked, preventing purging and allowing a visible layer of liquor to form on cake surface | Check if holes in filtering screen are blocked by product not removed during ploughing or by contaminants Increase duration of screen rinse time |
| <i>Shaft Rate</i> Vibration steadily increases to an excessive level during acceleration from feed to spin | Product cake has purged too quickly during feeding preventing it flowing to produce an even cake | Reduce feed speed Increase feed rate by increasing feed valve opening Check fed product does not have excessively large crystals |
| | Defective filtering screen allows 'ratholing' producing holes, gaps or depressions in cake surface | Check for holes in filtering screen Check for gaps between top and bottom edges of screen and basket Check for gaps at lock-lap joint in filtering screen |
| <i>Shaft Rate</i> Vibration rises to a peak and then falls during acceleration from feed to spin | Support structure is too flexible giving rise to a lateral resonance below spin speed | Increase stiffness of support structure (see Broadbent Information Sheet SI/96/1 or SI/97/1) Improve rigidity of connection between back of centrifuge upper frame and mixer tank (see Broadbent Information Sheet SI/96/1 or SI/97/1) |
| <i>Precession</i> during spinning | Anti-precession damper defective allowing rotating assembly to slowly orbit | Check damper spring settings (see drawings or manual) Check friction linings on damper plate not loose or worn Check centering ring is a tight fit on fan ducting |