

Lavatec LZ286 S

Fast cycling centrifugal extractor

LZ286 S

Fast cycling, automatic centrifugal extractor suitable for all classifications up to 60kg dry weight. With an innovative and efficient DC drive technology the LZ can cycle in as little as 2 minutes but still reach 800g ensuring the highest levels of moisture extraction. The flip-over design ensure unloading is quick and reliable.

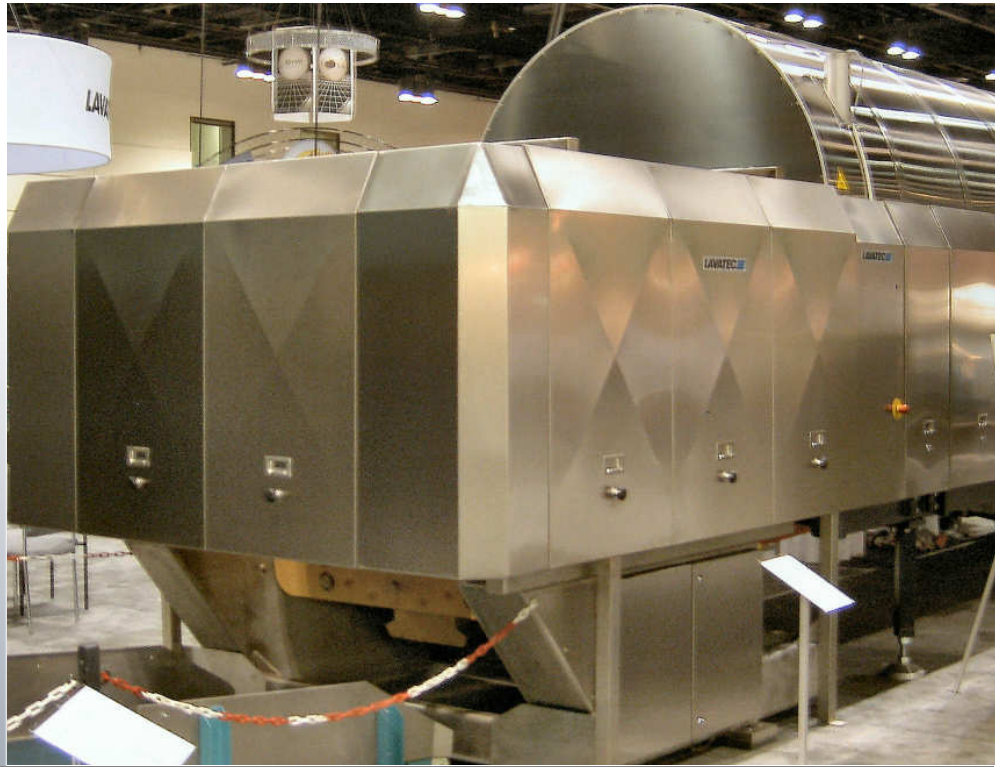

FEATURES

- Microprocessor control
- Energy efficient
- “Flip-over” unloading
- Heavy duty construction
- Unique drum design
- Built in recovery system

- Large simple interface, 99 extraction programs, interfaces with most washing systems
- Low running and maintenance costs, flexible DC drive technology
- Large opening and “flip-over” design ensure effective load & unload
- Very heavy construction, air suspension requires no special foundations
- Superior drum construction for excellent extraction properties & long life
- Built in recovery pump & tanks for reuse of extracted water

Thomas Broadbent & Sons Ltd.

Queen Street South
Huddersfield, England
HDI 3EA

Tel: +44 (0)1484 477200
Fax: +44 (0)1484 516142
E-mail: bls@broadbent.co.uk
www.broadbent.co.uk

Technical Data

Lavatec LZ286S centrifuge

Connected loads & consumption

	Consump'n	Conn. load
Electric	6kWh	40kW
Pneumatic	50l/cycle	6 Bar

Packing dimensions

Width	2870mm
Height	2310mm
Depth	2330mm

Connection details

	Key	Size
Pneumatic	DL	DN8
Rec' water	RF	DN50
Electric	EZ	
Drain	WA	DN100

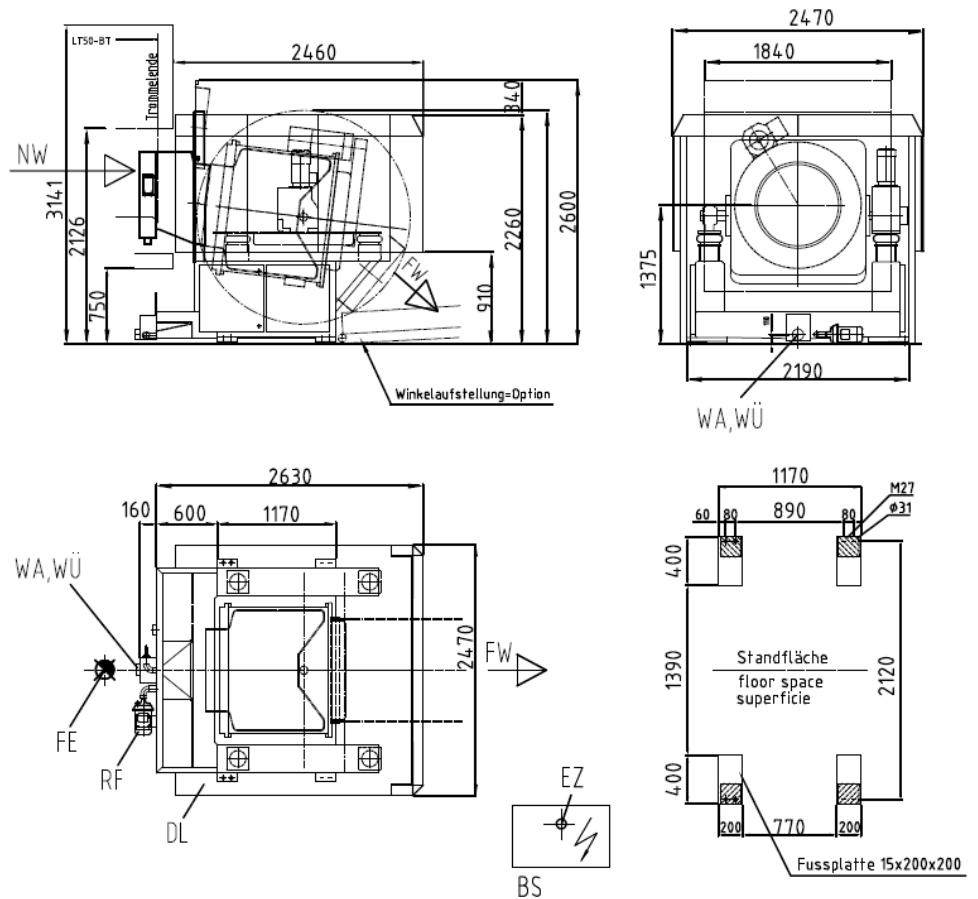

Drum volume

Drum dia 1180mm x 1080mm (1180 ltrs drum volume)

Performance

Cycle time min 120 secs, 8 - 1060 rpm, 800g

Loading capacity

Up to 60kg dry weight

Weight

Net 6000kg Operational 6200kg

Thomas Broadbent & Sons Ltd.

Queen Street South
Huddersfield, England
HDI 3EA

Tel: +44 (0)1484 477200

Fax: +44 (0)1484 516142

E-mail: bls@broadbent.co.uk

www.broadbent.co.uk