

INSTALLATION OPTION :

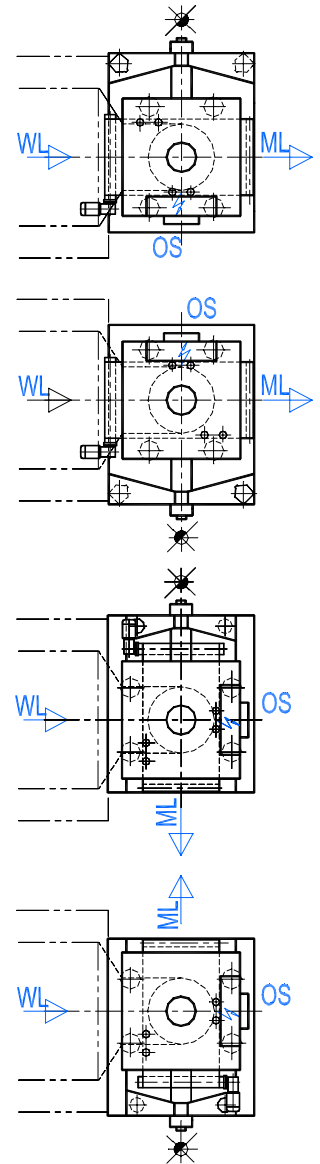

ADJUSTABLE LEG
DN 213, 4x

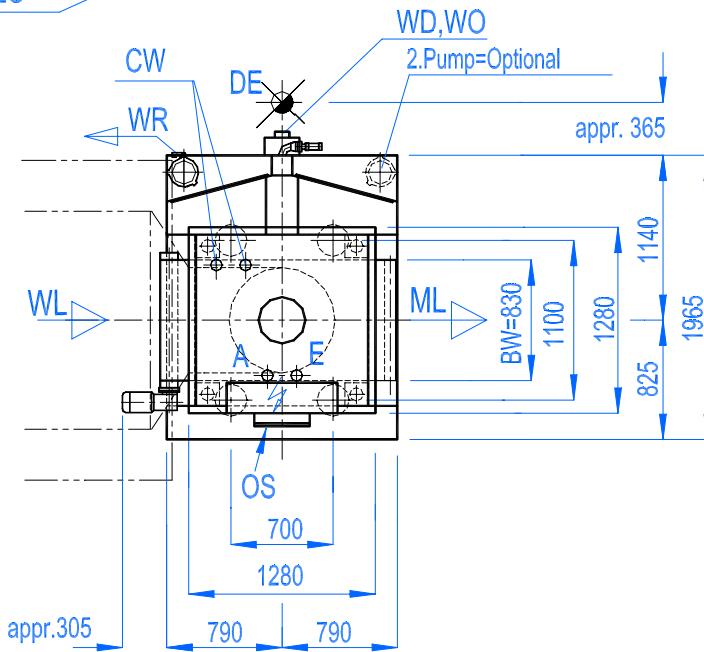

WL = Wet Linen
ML = Moist Linen
E = Electric Supply
WR = Water Recovery DN 50
WO = Water Overflow DN 100
WD = Water drainage DN 100
OS = Operation Side

D = Floor Drain
CW = Cooling Water in/out R3/4"
A = Compressed Air DN 6

Entrance Dimensions:
Height = 2350 mm
Width = 1650 mm

Recommended minimum wall
clearance = 900 mm

Subject to alterations

Documentation

Broadbent Laundry Systems
Queen Street South, Huddersfield

Edition 0004

LAVAPRESS

LP 560

SPECIFICATIONS

Capacity - dry weight	25 kg
Batch diameter (nominal)	730 mm
Cycle time (minimum)	150 sec
Moisture retention (DIN 11901) as per operating conditions	48 - 54 %
Electrical: connected load 6,7 kW	consumption approx. 5,1 kWh
Compressed air 6 bar, suction capacity	approx. 2 l / shift
Entrance dimensions, machine lowered, hydraulics not disconnected	W = 1650 mm, H = 2200 mm
Operational dimensions:	length 1600 mm, width 2100 mm, height 2900 mm
Operational weight	approx. 5700 kg
Transport weight	gross 5800 kg

APPLICATION

The Lavapress LP 560 is a single stage press for cyclic extraction of processed laundry batches consisting of 0 - 25 kg dry weight, transferred from the batch washer.

EXTRACTION

Even and consistent with a controlled pressure build up, using a water filled membrane pad mounted to the press stamp, that prevents damage to the laundry.

STANDARD VERSION

Solid steel construction consisting of a base section, columns and a head section.

Oil hydraulic and 100 litre filling

3 selectable pressure stages, e.g. 12, 18, max. 30 bar.

Pressure shut-off each pressure stage possible.

1 replacement pressure pad

In line, left or right angle installation is available

Chute for LAVATEC batch washer

Electric supply: 3 / N ~ 50 Hz, 400 / 230 V

Microprocessor control with operating display and manual control.

Laundry contact only with stainless steel parts.

Machine panelling made of stainless steel, wire-brushed-finish.

Large maintenance doors on two sides of machine.

Large water collection tank with pump device and drain connection.

Transport conveyor with drainage plate for safe batch transport from the press.

Machine equipped in accordance with relevant safety standards.

Pedestal for height adjustment.

Oil cooling, cooling water utilized in the batch washer approx. 300 l/h

SPECIAL VERSION

Programmable pressure control

Chutes for selected batch washers or customized installation

Conveyor - special length compensation by intermediate conveyor.

Electric: special voltage, special frequency, CSA -, Nema/UL-regulation.

Special finish.

ACCESSORIES

Transport units for batch transfer