

Dimensions and placement of components on the machine

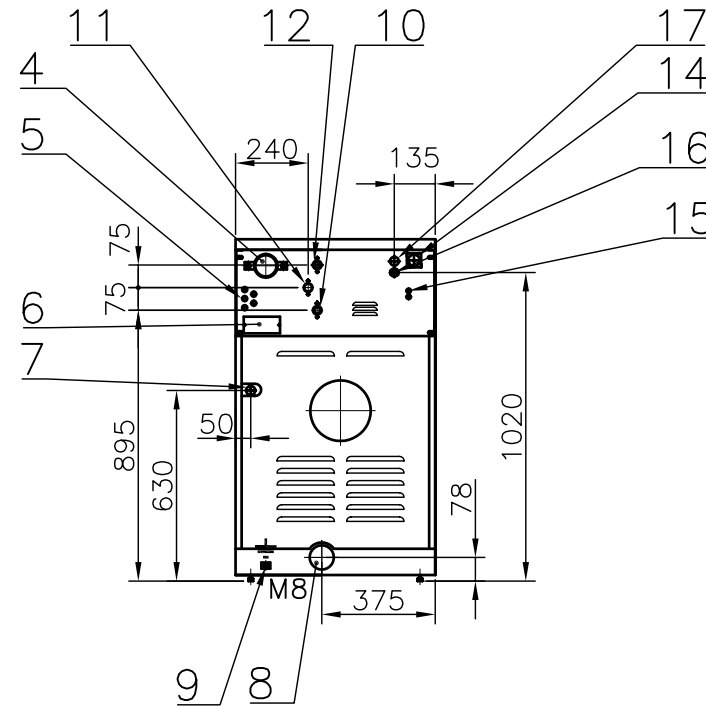

GROUND-PLAN VIEW

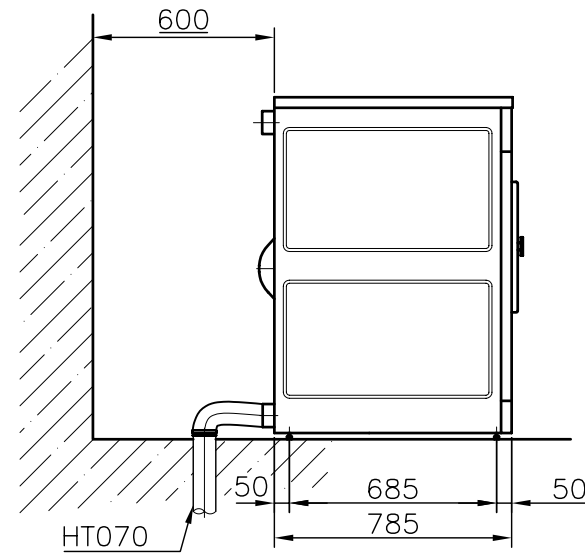
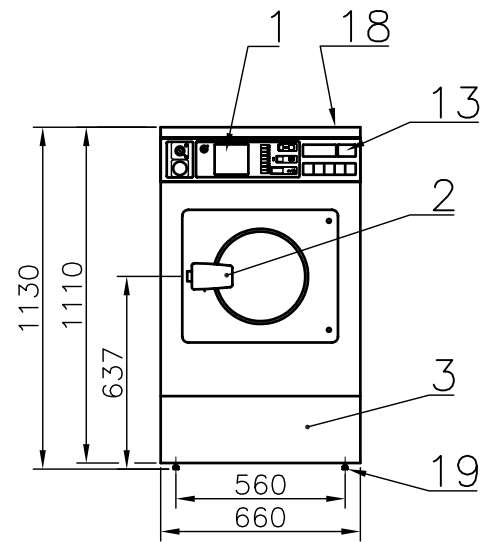
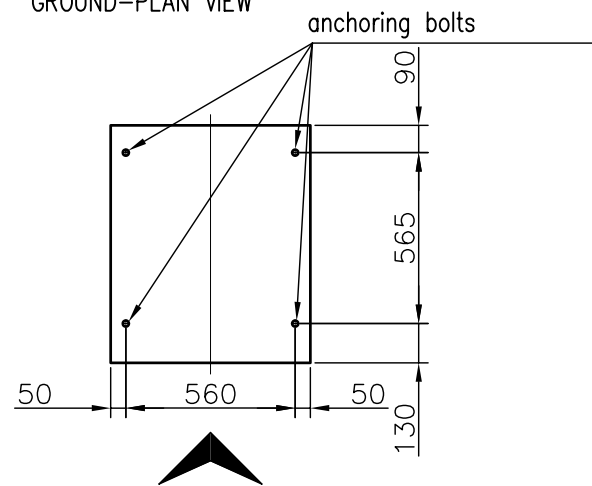

LEGEND:

- | | |
|--------------------------------|---------------------------------------|
| 1. Electronic programmer | 11. Cold soft water connection |
| 2. Door handle | 12. Cold hard water connection |
| 3. Service panel | 13. Control panel |
| 4. Air ventilation | 14. Main switch |
| 5. Liquid soap hose connection | 15. Fuses |
| 6. Name plate | 16. Main power supply |
| 7. Steam connection | 17. Power supply to liquid soap pumps |
| 8. Drain outlet | 18. Soap hoppers |
| 9. Earthing connection | 19. Adjustable leg |
| 10. Warm water connection | |

The machine must be located on a leveled concrete floor or on a elevation base ant should be secured by means of anchoring boltes to assure the safety.
The machine must reliably rest in all four corners of the machine!
The floor must comply static and dynamic stress.

Anchoring bolts are not part of delivery of machine.

WATER CONNECTION

The washing machine has been designed for connection of three waters (cold hard, cold soft and hot). It is also necessary to connect all available waters to a water supply.
Inlet valves 3/4" for cold and hot water are delivered with the machine. Mount shut-off valves 3/4" to the water supply pipes. For connection of the machine to water inlet shut-off valves we recomend to use enclosed flexible hoses with couplings 3/4".

WATER DRAIN CONNECTION

The washer is equipped with drain pipe of 75mm diameter without pump. These must be connected to the waste sump or central waste drain. For these purposes you can use rubber elbow, which is a part of delivery.
Put the stench trap in drain pipe.
The maximum temperature of waste water from washer is 70:80°C (for programm No.1 – hot washing).
Quantity of draining water – 56 l/min.

TECHNICAL SPECIFICATION

Capacity: load ratio 1:10	9.5 kg / 21 lbs
Inner drum dimension: diameter	530mm / 20.9"
depth	420mm / 16.5"
Drum volume	95 dm ³ / 25.1 gal
Drum revolutions: wash	48 rpm
high extraction	1000 rpm
G-factor:	300
Machine dimensions (max.): width	660mm / 26"
depth	865mm / 34.1"
height	1130mm / 44.5"
Weight netto	275 kg / 607 lb
brutto	300 kg / 662 lb
Machine electrical system:	3+N+PE~50Hz 400/230V / TN-S
Rated motor power:	1.5 kW
Rated heating power input (E version):	9 kW
Rated input power of the machine	E: 10.5 kW S: 1.5 kW
Power supply protection: with electrical heating:	9kW/3AC 400V/20A
without heating:	3AC 400V/16A
Motor overloading protection:	frequency convertor protection
Conductors section:	E: 5x4 mm ² Cu S: 5x2.5 mm ² Cu
Water connections: water pressure	0.2±0.6 MPa / 39±87 psi
water connection	3x 3/4"
drain connection	external diameter Ø76 mm / 3"
Version with steam heating (S): steam connection	1/2"
steam pressure	0.3±0.8 MPa / 45±116 psi
average steam consumption:	10 kg/hod / 22 lb/hour
maximum steam consumption:	0.01 kg/sec / 0.022 lb/sec
Connections to liquid detergents:	5
Max. static load (with textile and water)	300 kg / 661.4 lb
Max. dynamic load (intermittent vibrations)	±110 kg / ±242.5 lb
Frequency of dynamic load	16 Hz

lavamac	LH 95	Date:	25.04.01	No.	01-132-2.1
		Author:	T.R.	Index/date	C/09.2006
		WASHER - EXTRACTOR			