

MACHINE	Dimension "L" [m]
LSRP 5020 G	1.6
LSRP 5025 G	2.2
LSRP 5032 G	2.8

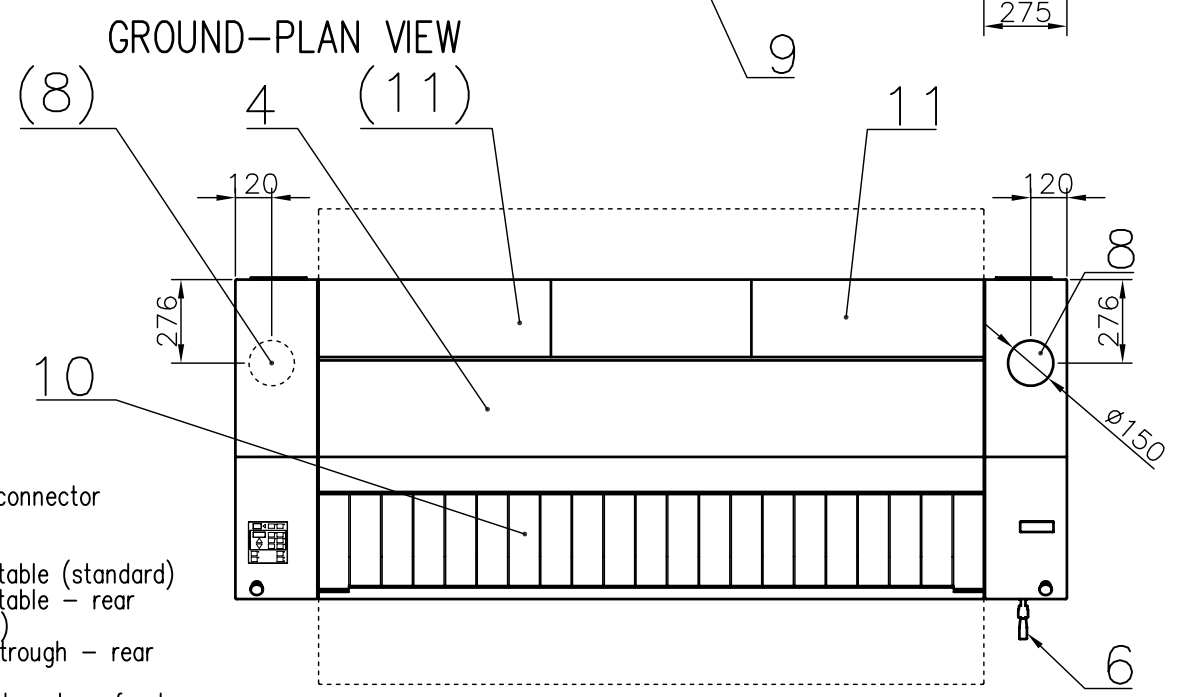

**LEGEND:**

- 1. Control panel
- 2. Main switch
- 3. Name plate
- 4. Upper cover
- 5. Emergency stop
- 6. Manual drive of roller
- 7. -
- 8. Exhaust ventilation
- 9. Pedal used for starting/stopping belts movement
- 10. Insertion belts
- 11. Cover of filter sieve
- 12. Upper trough
- 13. Main power supply
- 14. External protective connector
- 15. Gas supply
- 16. -
- 17. IF - Output tilting table (standard)
- 18. IF - Output tilting table - rear (according to order)
- 19. IR - Output tilting trough - rear (standard)
- 20. IR - Output tilting trough - front (according to order)

**EXHAUST SYSTEM:**

The ironer produces hot humid air (temp. 70÷90°C), combustible lint and toxic gas. To reduce a risk of fire and health problems the dryer must be exhausted to the outdoors by means of exhaust duct connected to exhaust piping.

The design of the flue system shall be such that any a condensate formed when operating the appliance from cold shall either be retained and subsequently re-evaporated or discharged.

If possible, do not install dryers and gas fired hot water heaters or the other gravity vented appliances in the same room.

Use exhaust ducts made of sheet metal or other noncombustible material.

The ironer requires an action related to air which replaced the air exhausted from the ironer. Opening(s) for air supply from outside of the building should be as close to the machine as possible.

Aerating opening(s) for the make-up air supply required per each individual ironer is 0,18 m<sup>2</sup> (for machine with two outlets - 0.36m<sup>2</sup>).

**GAS CONNECTION:**

Gas installation have to conform to local standards and rules. Install upstream of each ironer a manually operated gas shut-off valve on an easily accessible place. Install a dirt and water vapour pipe trap per each ironer gas supply.

Connect machine supply screwed-fitting and gas shut-off valve through the use of flexible gas hose.

Gas hoses and gas shut-off valves aren't part of machine delivery. Install pressure gauge between pressure reduction valve and manually operated gas shut-off valve because of gas pressure check.

MARK:	LSRA 5020	LSRA 5025	LSRA 5032
- without folder	LSRP 5020	LSRP 5025	LSRP 5032
- with folder	LSRP 5020	LSRP 5025	LSRP 5032
Max. feeding width - B	2000mm/79"	2500mm/98"	3200mm/126"
Machine width - A	2750mm / 108.3"	3350mm / 132"	3950mm / 155.5"
Roller diameter	500mm / 19.7"	500mm / 19.7"	500mm / 19.7"
Roller length	2100mm / 82.7"	2700mm / 106.3"	3300mm / 130"
Ironing speed	1.5 ÷ 8m/min / 5 ÷ 26'/min		
Weight netto / brutto			
- LSRA	1260kg / 1500kg 2778 lb / 3307 lb	1420kg / 1670kg 3131 lb / 3682 lb	1660kg / 1980kg 3660 lb / 4365 lb
- LSRP	1290kg / 1520kg 2844 lb / 3351 lb	1440kg / 1700kg 3175 lb / 3748 lb	1680kg / 2000kg 3704 lb / 4409 lb
Air outlet	ø150 mm	2x ø150 mm	2x ø150 mm
Min. air flow	500 m3/hour	2x 500 m3/hour	2x 500 m3/hour
Optimum air flow	990 m3/hour	2x 990 m3/hour	2x 990 m3/hour
Max. static back pressure at pipeline	233 Pa / 0.034psi	2x 233 Pa / 2x 0.034psi	2x 233 Pa / 2x 0.034psi
<b>GAS</b>			
Heating power	36 kW	52 kW	66 kW
Gas supply	¾"	¾"	¾"
Installation code	B22	B22	B22
<b>ELEKTRICAL DATA</b>			
Drive power	0.37 kW	0.37 kW	0.37 kW
Fun power	0.18 kW	2x 0.18 kW	2x 0.18 kW
Voltage system	3+N+PE~50Hz 400/230V / TN-S		
Installed load	0.7 kW	0.9 kW	0.9 kW
Amps	10 A	10 A	10 A
Conductor section	5x1.5 mm <sup>2</sup> Cu	5x1.5 mm <sup>2</sup> Cu	5x1.5 mm <sup>2</sup> Cu
Sound of pressure level	67.6 dB (A)	67.6 dB (A)	67.6 dB (A)

<b>lavamac</b>	<b>LSRA50 LSRP50 G</b>	Datum:	08/2006	No.	03-108-2.3
		Autor:	RJ	Index/datum	
<b>IRONING MACHINE WITH FRONT/REAR DELIVERY</b>					