

MACHINE	Distance "L" [m]
LSR 5016 S	0.7
LSR 5020 S	0.7
LSR 5025 S	0.7
LSR 5032 S	0.7

- LEGEND:**
- Control panel
  - Main switch
  - Name plate
  - Upper cover
  - Emergency stop
  - Manual drive of roller
  - Ironing belts
  - Exhaust ventilation
  - Pedal, used for starting/stopping belts movement
  - Insertion belts
  - Cover of filter sieve
  - Upper trough
  - Lower trough
  - Main power supply
  - Steam supply inlet
  - Steam outlet
  - External protective connector

**EXHAUST SYSTEM:**

The dryer produces hot humid air (temperature 70±90°C) and combustible lint. To reduce a risk of fire the dryer must be exhausted to the outdoors by means of exhaust duct connected to exhaust piping.

The design of the flue system shall be such that any a condensate formed when operating the appliance from cold shall either be retained and subsequently re-evaporated or discharged. If possible, do not install dryers and gas fired hot water heaters or the other gravity vented appliances in the same room.

Use exhaust ducts made of sheet metal or other noncombustible material. The dryer requires an action related to air which replaced the air exhausted from the dryer. Opening(s) for air supply from outside of the building should be as close to the dryer(s) as possible.

Aerating opening(s) for the make-up air supply required per each individual ironer is 0,13 m<sup>2</sup> (for machine with two outlets – 0,26m<sup>2</sup>).

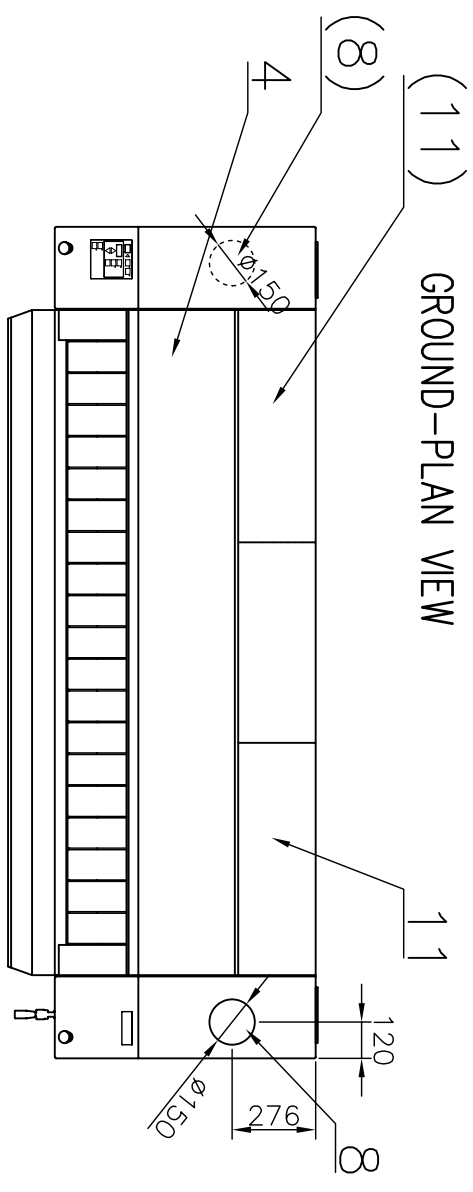
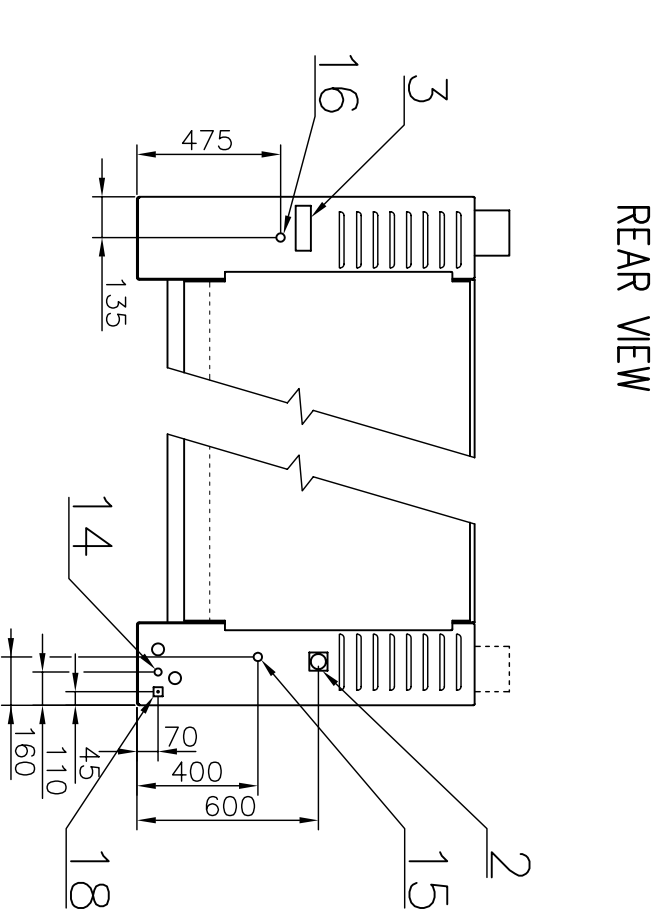

**STEAM CONNECTION**

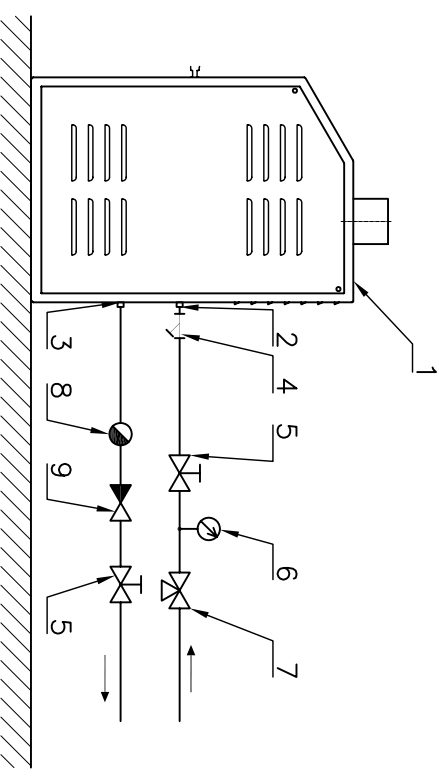

1. Ironer
2. Steam supply inlet (G3/4")
3. Steam outlet (G3/4")
4. Filter (part of delivery)
5. Manual steam shut-off valve
6. Manometer
7. Drainage cock
8. Steam trap with built-in strainer
9. Vacuum breaker

MARK	LSR 5016	LSR 5020	LSR 5025	LSR 5032
Max. feeding width – B	1600mm/63"	2000mm/79"	2500mm/98"	3200mm/126"
Machine width – A	2350mm 92.5"	2750 mm 108.3"	3350 mm 132"	3950 mm 155.5"
Roller diameter	500 mm 19.7"	500 mm 19.7"	500 mm 19.7"	500 mm 19.7"
Roller length	1700 mm 67"	2100 mm 82.7"	2700 mm 106.3"	3300 mm 130"
Ironing speed	1.5÷8m/min / 5÷26'/min			
Weight netto / brutto	900kg/1100kg 1984lb/2425lb	1070kg/1280kg 2359lb/2822lb	1280kg/1490kg 2822lb/3285lb	1540kg/1800kg 3395lb/3968lb
Air outlet	Ø150mm / Ø5"	Ø150mm / Ø5"	2x Ø150mm / 2x Ø5"	2x Ø150mm / 2x Ø5"
Min. air flow [m3/hour]	500	500	2x 500	2x 500
Optimum air flow [m3/hour]	990	990	2x 990	2x 990
Max. static back pressure at pipeline	233Pa / 0.034psi	233Pa / 0.034psi	2x 233 Pa / 2x 0.034psi	2x 233 Pa / 2x 0.034psi
Steam connection	G3/4"	G3/4"	G3/4"	G3/4"
Steam pressure	0.8÷1.0MPa / 45÷116psi	0.8÷1.0MPa / 45÷116psi	0.8÷1.0MPa / 45÷116psi	0.8÷1.0MPa / 45÷116psi
Condensate outlet	G3/4"	G3/4"	G3/4"	G3/4"
Average steam consumption (for 0.9MPa)	36kg/hod / 59.5lb/hour	49kg/hod / 70.5lb/hour	88kg/hod / 88.2lb/hour	88kg/hod / 88.2lb/hour
<b>ELECTRICAL DATA</b>				
Drive power	0.37 kW	0.37 kW	0.37 kW	0.37 kW
Fun power	0.18 kW	0.18 kW	2x 0.18 kW	2x 0.18 kW
Voltage system	3+N+PE ~50Hz 400/230V / TN-S			
Installed load	0.7 kW	0.7 kW	0.9 kW	0.9 kW
Amps	10 A	10 A	10 A	10 A
Conductor section	5x 1.5mm <sup>2</sup> Cu	5x 1.5mm <sup>2</sup> Cu	5x 1.5mm <sup>2</sup> Cu	5x 1.5mm <sup>2</sup> Cu
Sound of pressure level	67.6 dB (A)	67.6 dB (A)	67.6 dB (A)	67.6 dB (A)

lavamac

LSR 50.. S

CYLINDER HEATED IRONER

Datum:	03.3.03	No.	03-106-2.2
Autor:	T.R.	Index/datum	C/08.2006