

RIGHT SIDE VIEW

minimum recommended for maintenance purposes

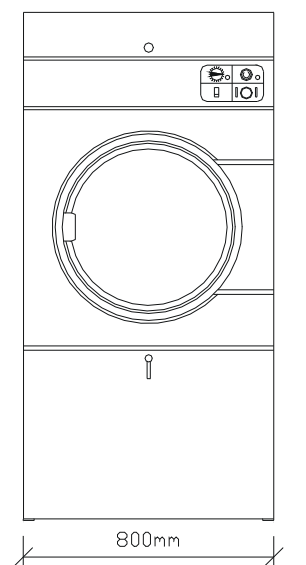

FRONT VIEW

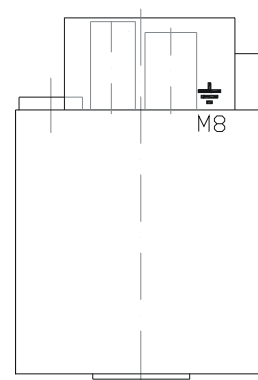

PLAN VIEW

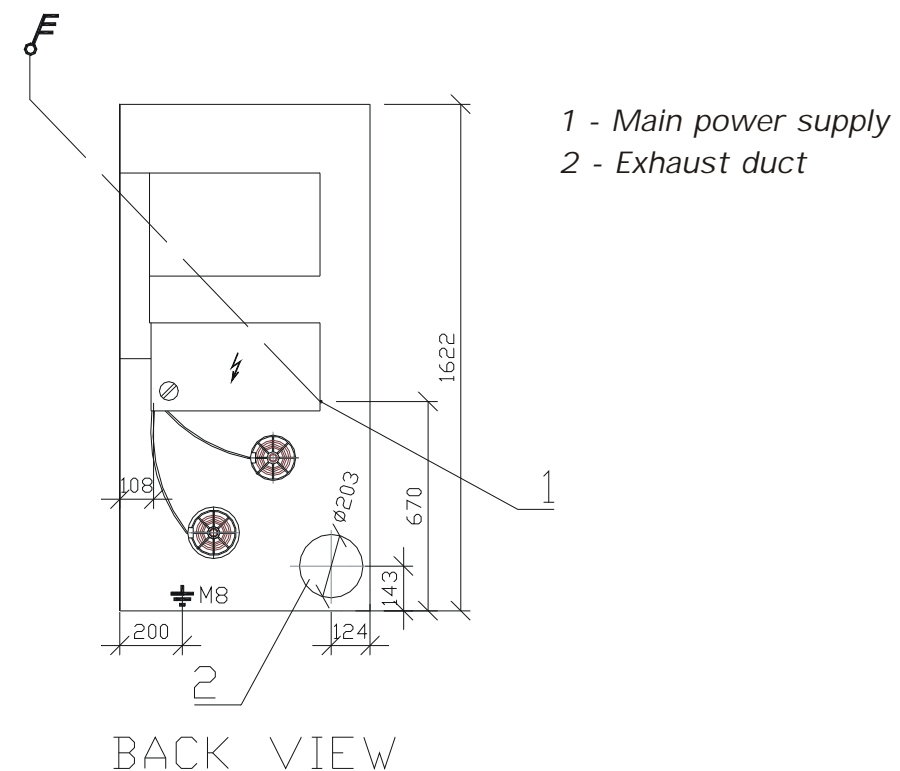

BACK VIEW

1 - Main power supply
2 - Exhaust duct

For maximum efficiency and minimum lint accumulation, tumbler air must be exhausted to outdoors by shortest route.

Exhaust ducts shall be constructed of sheet metal or other noncombustible material.

Maximum allowable length to venting is 14 feet(4.3m) and two 90°elbows or equivalent. If equivalent length of a duct required for installation exceeds maximum allowable equivalent length, diameter of a round duct must be increased by 10% for each additional 20 feet(6.1m).

90°elbow quantity	maximum length of metal duct $\varnothing 203$
0	9.96 m
1	7.13 m
2	4.3 m

-for additional elbow extra is need subtract 2.83 m

With tumbler in operation, airflow at any point in duct must be at least 1200 feet (366m) per minute to insure that remains airborne.

There is possible to join max. 6 tumblers at the collector duct, individual tumbler ducts must enter at a 45°angle in direction of air flow. Never connect a tumbler duct at a 90°angle to collector duct.

Recommendation duct enlargement:

quantity	min. duct diameter
2	305
3	381
4	432
5	483
6	533

Technical specification:

Capacity:	
Max. load ratio 1:22	15.9 kg
Drum dimension:	$\varnothing 762 \times 762$ mm
Drum volume:	347 dm ³
Electrical system:	3+PEN 400V, 50Hz
Electrical input:	27.45 kW
Safe-guarding:	60 Amp
Conductors section:	4x10 mm ² Cu
Motor power:	0,25 kW
Ventilator power:	0,2 kW
Max. air flow:	800 m ³ /hour
Pressure:	125 Pa
Dimensions: width	800 mm
depth	1140 mm
height	1622 mm
Weigh: net	170 kg
gross	205 kg

 LAUNDRY SYSTEMS	LDR350 E	Date	26.2.03	No	06-102-2.1
		Author	T.R.	Index	
		INDUSTRIAL TUMBLER DRYER			