

LEGEND

1. Electronic control
2. -
3. Emergency stop button
4. Door
5. Gas inlet
6. -
7. Main switch
8. Main power supply
9. Air outlet
10. Suction
11. -
12. -
13. Lint screen cover

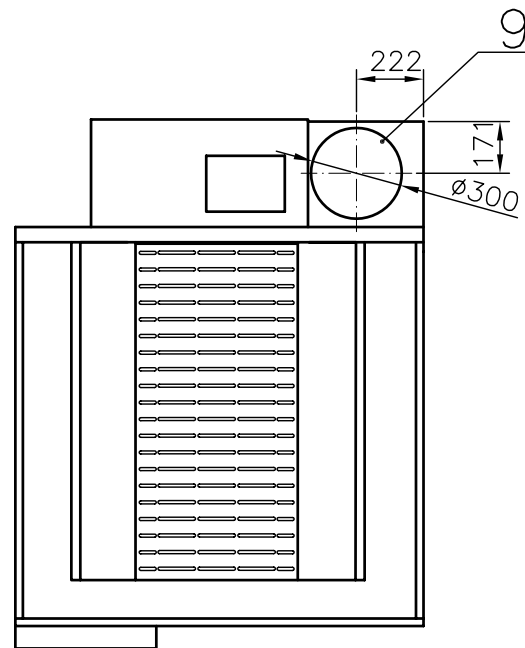

GAS CONNECTION:

Gas installation have to conform to local standards and rules.
 Install upstream of each dryer a manually operated gas shut-off valve on an easily accessible place, so that the guiding length from the valve to the machine connecting is less than 2m.
 Install a dirt and water vapour pipe trap per each dryer gas supply.
 Connect machine supply screwed-fitting and gas shut-off valve through the use of flexible gas hose.
 Gas hoses and gas shut-off valves aren't part of machine delivery.
 Install pressure gauge between pressure reduction valve and manually operated gas shut-off valve because of gas pressure check.

EXHAUST SYSTEM:

The dryer produces hot humid air (maximum temp. 90°C), combustible lint and toxic gas. To reduce a risk of fire and health problems, the dryer must be exhausted to the outdoors by means of exhaust duct connected to exhaust piping.
 The design of the flue system shall be such that any a condensate formed when operating the appliance from cold shall either be retained and subsequently re-evaporated or discharged.
 If possible, do not install dryers and gas fired hot water heaters or the other gravity vented appliances in the same room.
 The industrial dryer may be located only in ventilated space.
 Use exhaust ducts made of sheet metal or other noncombustible material.
 The dryer requires an action related to air which replaced the air exhausted from the dryer. Opening(s) for air supply from outside of the building should be as close to the dryer(s) as possible.
 Aerating opening(s) for the make-up air supply required per each individual dryer is 0,37 m².

MACHINE DIMENSIONS

Width	1350 mm
Depth	1675 mm
Height	2388 mm
Cylinder - diameter	1289 mm
- depth	1080 mm
- capacity	1408 l
Net weight	716 kg
Air outlet	ø300 mm
Maximum air flow	4161 m ³ /hod
Max. static back pressure at pipeline	80 Pa
GAS	
Heating power	115,7 kW
Gas connection	G1"
Gas pressure	G20 ... 20 mbar G30-G31 ... 30 mbar
Installation code	B ₂₂
ELECTRICAL DATA	
Power - drive	0,56 kW
- fun	2,2 kW
Voltage system	3+NPE 400 V, 50 Hz
Amps	16 A
Conductor section (mm ² Cu)	4x 2,5
Execution of internal protection	IP 43
Sound of pressure level	66 dB (A)

lavamac	LDR 1425 G	Date:	11/2005	No.	06-107-2.3
		Author:	RJ	Index/date	
TUMBLE DRYER					