

Elise

Flaking and strapping machine
for towel rolls

laundry machines

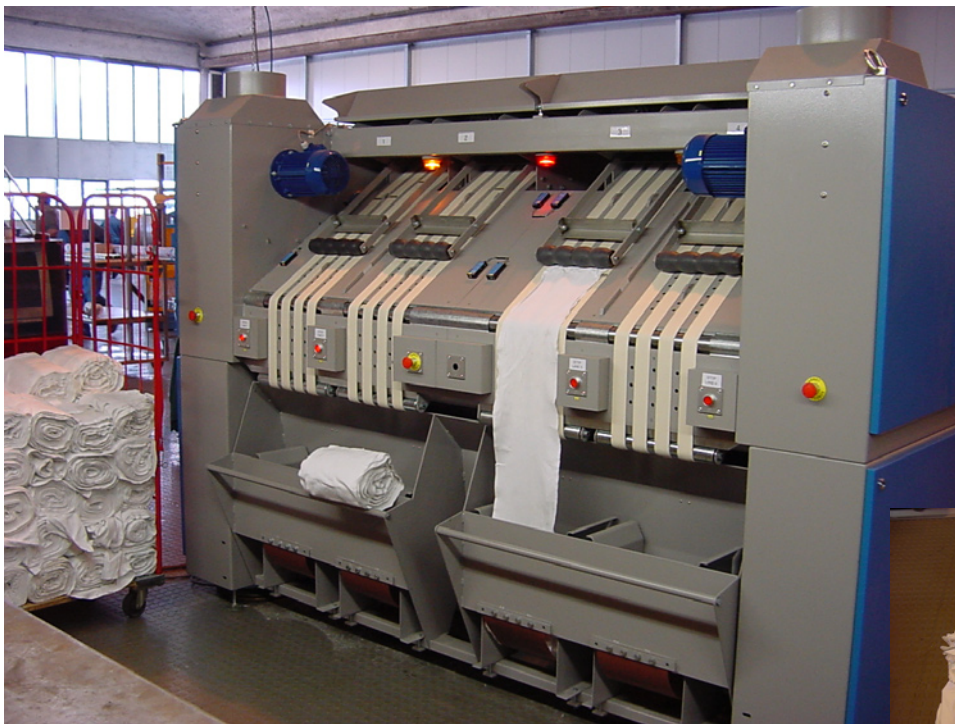

Towel rolls with a typical length of 35...40 m are flaked out on four independent lanes by a swinging arm on each lane.

The four lanes can be operated by only one person, synchronization of the lanes in order to avoid collisions at the strapping machines or laundry bag is provided by software.



The towels are laid down on four conveyors, lay down of the leading edge is controlled by the PLC system for exact positioning. For each two lanes a strapping machine and transport conveyor to the laundry bag is provided.

The strapping machines have to be supplied by the customer, different types can be installed and connected to the control system of the flaking machine. Before binding, the flaked towel is folded lengthwise, one or two bindings per towel can be programmed.

Processed towels are counted and laundry bag replacement is performed automatically after reaching the programmed number of towels.

The de-rolling speed can be adjusted up to 130 m/min.

The theoretical performance of the machine is up to 640 rolls/hour.

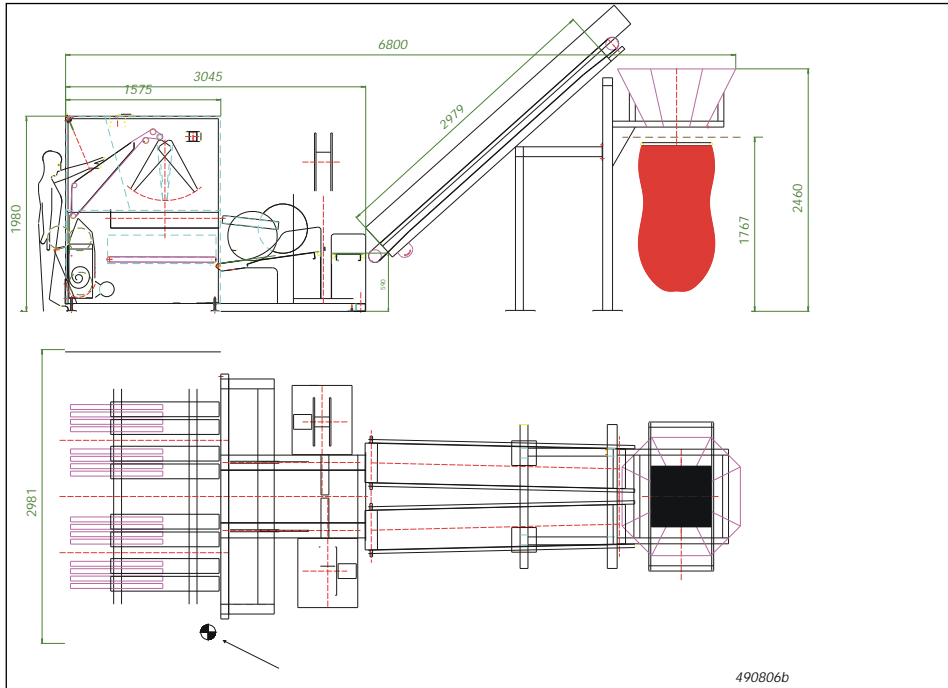

Technical Specifications:

Electrical Connection:
3 x 400 V, 50 Hz, 6.5 kW

Air:
6 bar
Connection: \varnothing 8mm
Consumption: 1m³/h

Weight:
1400 kg

Size of pieces: Towel rolls of 35...40 m length, 20...32 cm width

Standard equipment:

- Vacuum feeding conveyor
- Four independent lanes
- Start/stop operation for each lane
- Control of one strapping machine (to be supplied by the customer) for each two lanes
- Transport conveyor and funnel to the laundry bag
- Integrated control of flaking machine, strapping machine and signaling for laundry bag replacement
- Prepared for connection of absorber on feeding conveyor

Additional equipment:

- Absorber on feeding conveyor
- Integrated lifts for towel carrier
- Transport conveyor for special requirements
- Special colour
- Spare part set

Manufacturer: BIKO Engineering AG, Moserstrasse 15, CH-3421 Lyssach

Technical changes reserved
920753

Agency: